



## Himrrs / Hirrs



UIC	TWA	Dispo-Gruppe	NW
Himrrs	NHM2	KRD	Himrrs 022
Hirrs	NHM4	KRD	Hirrs 004

## Himrrs / Hirrs

 Wagentdaten	 Wagon data	 Caractéristiques techniques	 Caratteristiche tecniche	 Vagndata	 Dane wagonu	 Vagon detayları	NHM2	NHM4
Dispo-Gruppe	Order group	Code groupe	Gruppo Dispo	Dispogrupp	Typ wagonu	Vagon Grubu		
Profil	Gauge	Gabarit	Profilo	Profil	Profil	Gabari	<b>G 1</b>	<b>G 1</b>
Wagenlänge über Puffer	Overall length over buffers	Longueur hors tout	Lunghezza carro tra i respingenti	Längd över buffertar	Długość wagonu ze zderzakami	Tamponlar arası uzunluğu	<b>31.000 mm</b>	<b>30.280 mm</b>
Ladelänge	Loading length	Longueur utile	Lunghezza del piano di carico	Lastytans längd	Długość przestrzeni ładunkowej	Yükleme Boyu	<b>2 x 14.240 mm</b>	<b>2 x 13.870 mm</b>
Ladebreite	Loading width	Largueur utile	Larghezza del piano di carico	Lastytans bredd	Szerokość przestrzeni ładunkowej	Yükleme Eni	<b>2.900 mm</b>	<b>2.895 mm</b>
Ladefläche	Loading area	Superficie utile	Superficie di carico	Lastyta	Powierzchnia ładunkowa	Yükleme Alanı	<b>2 x 41,3 m²</b>	<b>2 x 40,2 m²</b>
Laderaum	Loading volume (cube)	Volume utile	Volume di carico	Lastvolym	Pojemność ładunkowa	Yükleme Hacmi	<b>2 x 108 m³</b>	<b>2 x 106 m³</b>
Schiebewandöffnung - Höhe	Access height when sliding doors fully opened/retracted	Ouverture des portes (hauteur)	Apertura parete scorrevole - Lunghezza	Skjutdörröppning - höjd	Wysokość otworu po otwarciu drzwi przesuwanych	Kapı Ölçüleri - Yüksekliği	<b>2.800 mm</b>	<b>2.790 mm</b>
Schiebewandöffnung - Breite	Access width when sliding doors fully opened/retracted	Ouverture des portes (largeur)	Apertura parete scorrevole - Larghezza	Skjutdörröppning - bredd	Szerokość otworu po otwarciu drzwi przesuwanych	Kapı Ölçüleri - Eni	<b>7.000 mm</b>	<b>6.820 mm</b>
Fußbodenhöhe über Schienenoberkante	Height of wagon floor over rail	Hauteur du plancher au-dessus du rail	Altezza del piano di carico dal piano rotaia	Lastytans höjd över rälsöverkant	Wysokość podłogi nad główką szyny	Platformun Raydan Yüksekliği	<b>1.200 mm</b>	<b>1.200 mm</b>
Zulässige Fußbodenbelastung	Maximum floor pressure allowed	Limite de charge du plancher	Limite di portata del pavimento	Högsta tillåtna golvbelastning	Dopuszczalna obciążenie podłogi	Maksimum Taban taşıma kapasitesi	<b>50 kN</b>	<b>30 kN</b>
Eigengewicht	Tare weight	Tare	Tara	Egenvikt	Masa własna	Darası	<b>ca. 30.000 kg</b>	<b>ca. 30.000 kg</b>
Lastgrenze D	Payload D	Limite de charge sur ligne D	Limite di portata (Linee classe D)	Lastgräns D	Dopuszczalna masa brutto (klasa D)	Yükleme Sınırları (D Hatları)	<b>ca. 60,0 t</b>	<b>ca. 60,0 t</b>
Lastgrenze C	Payload C	Limite de charge sur ligne C	Limite di portata (Linee classe C)	Lastgräns C	Dopuszczalna masa brutto (klasa C)	Yükleme Sınırları (C Hatları)	<b>ca. 52,0 t</b>	<b>ca. 52,0 t</b>
Kleinster befahrbarer Gleisbogenhalbmesser	Minimum curve radius	Rayon minimum de passage en courbe	Raggio minimo di curvatura	Minsta kurvradie	Minimalny promień skrętu	En az Kurp Yarçapı	<b>75 m</b>	<b>75 m</b>
Palettenkapazität - Euro-Paletten	Pallet capacity - Euro Pallets	Nombre de palettes européennes	Capacità di carico - Euro-palette	Pallkapacitet - Eur-Pallar	Ilość palet - europalety	Palet Kapasitesi (Adet) EUR	<b>80 units</b>	<b>78 units</b>
Palettenkapazität - Industriepaletten	Pallet capacity - Industrial Pallets	Nombre de palettes industrielles	Capacità di carico - Palette industriali	Pallkapacitet - industriepallar	Ilość palet - palety przemysłowe	Palet Kapasitesi (Adet) EUR3 ve Universal	<b>56 units</b>	<b>52 units</b>
<b>Zusatzdaten pro Wagenhälfte</b>	<b>Extra information by half wagon</b>	<b>Données complémentaires par demi-wagon</b>	<b>Dati supplementari per semicarro</b>	<b>Tilläggsdata per vagnhalva</b>	<b>Dodatkové informácie do jednotky wagonu krátkosprężonego</b>	<b>Vagon Yarısı için diğer bilgiler</b>		
Verzurrösen (seitlich)	Securing rings (on side)	Anneaux d'arrimage (latéraux)	Occhielli di ancoraggio (laterali)	Lastsäkringsöglor - (på sidorna)	Uchwytły do lin zabezpieczających ładunek (boczne)	Sabit kancalar - Yan Duvar	<b>24 units</b>	<b>16 units</b>
Tragfähigkeit	Payload	Capacité de charge	Portata	Lastförmåga	Dopuszczalny ciężar ładunku	Yükleme Kapasitesi	<b>ca. 30,0 t</b>	<b>ca. 30,0 t</b>

## Himrrs (NHM2)

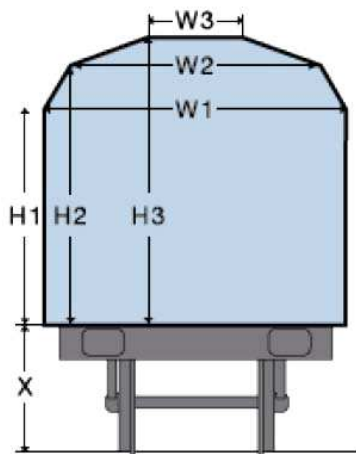
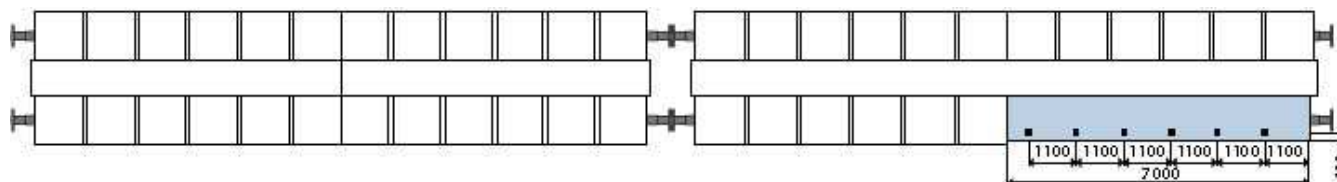

Lastgrenzraster

	A	B	C	D	
S	34,0 t	42,0 t	52,0 t	60,0 t	★ ★
120	0,0 t				

40 EUR-Paletten (800 x 1200)



28 Industriepaletten (1000 x 1200)



NHM2			
Höhe über Fußboden	Vorhandene Ladebreite im Wandbereich		
<b>H1</b>	<b>2100</b>	<b>W1</b>	<b>2900</b>
	2150		2842
	2200		2784
	2250		2726
	2300		2668
	2350		2610
	2400		2551
	2450		2493
	2500		2435
<b>H2</b>	<b>2520</b>	<b>W2</b>	<b>2412</b>
	2550		2248
	2600		1974
	2650		1700
	2700		1426
	2750		1152
<b>H3</b>	<b>2800</b>	<b>W3</b>	<b>878</b>

## Hirrs (NHM4)

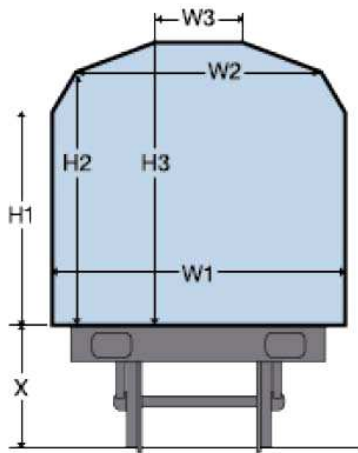
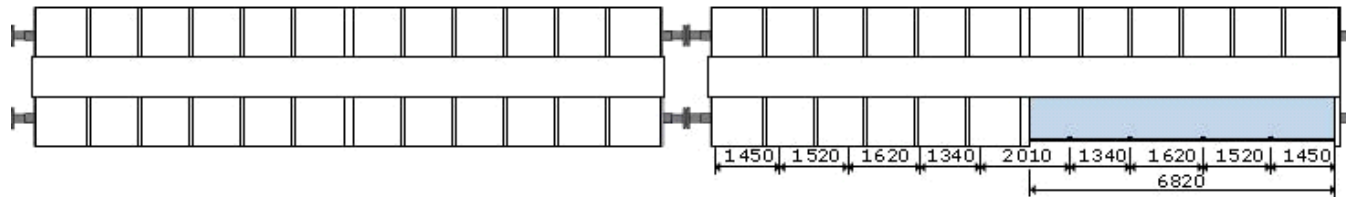

Lastgrenzraster

	A	B	C	D	
S	34,0 t	42,0 t	52,0 t	60,0 t	★ ★
120	0,0 t				

39 EUR-Paletten (800 x 1200)



26 Industriepaletten (1000 x 1200)



NHM4			
Höhe über Fußboden	Vorhandene Ladebreite im Wandbereich		
<b>H1</b>	<b>2100</b>	<b>W1</b>	<b>2895</b>
	2150		2836
	2200		2776
	2250		2717
	2300		2658
	2350		2598
	2400		2539
	2450		2479
<b>H2</b>	<b>2500</b>	<b>W2</b>	<b>2420</b>
	2550		2154
	2600		1888
	2650		1622
	2700		1357
	2750		1091
<b>H3</b>	<b>2790</b>	<b>W3</b>	<b>878</b>